

turbocut

VIHSSCHUSSAPPARATE

captive bolt stunner device

caliber 9 x 17mm - central fire



Blitz model series:

Blitz Kerner

Bullen Blitz

Kleiner Blitz

Blitz Schlag



DE-17-MARLIV18-PTB01

operating instructions
(translation)

dated: December 2021



Foreword

Please ensure that you read through these operating instructions (dated: 12/2021) before first use!

Please read through the safety instructions carefully to ensure safe and correct use. Always keep these operating instructions safely with the captive bolt stunner device



The captive bolt stunner may be passed on to other trained persons only with these operating instructions.



You will find several translations of this instruction manual as well as further information on our homepage www.turbocut.de.

You will find several translations of this manual instruction as well as further information on our homepage www.turbocut.de



For further information, please scan this QR code:

Scope of supply

Please check the delivery for completeness and damage. Should parts be missing or defective, please contact your supplier immediately.

Number	Designation
1 x	Blitz captive bolt stunner (packed in oil paper)
1 x	operating instructions
1 x	cleaning set (cleaning rod, large and small brush)

Manufacturer:

turbocut Jopp GmbH
D-97616 Bad Neustadt an der Saale

Contact :

turbocut Jopp GmbH
Donsenhaus 4
D-97616 Bad Neustadt an der Saale
Telefon: +49 (0) 9771 / 9105-363
Fax: +49 (0) 9771 / 9105-368
E-Mail: info@turbocut.de
Internet: www.turbocut.de



Table of contents

Foreword	2
1. General information	4
1.1 Intended use	
1.2 Pictograms	4
1.3 Identification details	
1.4 Transferring the information	5
2. Safety instructions	5
2.1 Basic safety information/official safety regulations	5
2.2 Improper use	
2.3 Latest engineering practice	
2.4 Appropriate use and environment	6
2.5 General hazards caused by the device	
2.6 Thermal hazard	
2.7 Cartridges that fail to fire	
2.8 Requirements for the user and personnel restrictions	7
2.9 Personal protective equipment	8
3. Description	8
4. Blank cartridges and their storage	9
5. First use	10
5.1 Checking the device	10
5.2 Alternative testing methods	11
6. Operating the device	11
6.1 Loading.....	11
6.2 Cocking	
6.3 Firing	12
6.4 Removing the fired blank cartridges	13
6.5 Positioning for different animals.....	14
6.6 Signs of a good stunning effect.....	17
7. Troubleshooting	18
8. Maintenance and care	19
9. Disposal	20
10. Technical data	21
11. Test specifications and repeat testing	22
12. Manufacturer warranty	23
13. Appendix	24
13.1 Sketches of the captive bolt stunner types	24
13.2 Accessories and individual parts lists	26
14. Declarations of conformity	29
15. For your notes	33
16. Important information on purchase certificate	35

1. General information

Please ensure that you read through these operating instructions before first use! In this text, the term "the device" refers in all instances and exclusively to the respective variant of the Blitz captive bolt stunner.

SIGNAL WORDS AND THEIR MEANINGS

Warning level	Consequences	Probability
 Danger	Death or severe, irreversible injuries	Directly impending danger
 Warning	Death or severe, irreversible injuries	Potentially hazardous situation
 Caution	Slight or minor, reversible injuries	Potentially hazardous situation
Note	Property damage	Potentially hazardous situation

1.1 Intended use

Blitz captive bolt stunners are intended exclusively for the stunning of animals for slaughter. Any use other than this is considered improper use. Regulation 1099/2009 (EC) of the Council on the protection of animals at the time of killing and the applicable national regulations must be observed by the operator.

1.2 Pictograms

		 	
Caution	Hot surface/warning - explosive atmosphere	Wear hearing protection /use hand protection	Observe the operating instructions

1.3 Identification details

Location of the identification details on the device:

Headpiece	Production year, serial number
Sleeve	Manufacturer, model series, production year, serial number, product name, ammunition type

1.4 Transferring the information

Copy the following information into your operating instructions and always quote this when making inquiries or when submitting for repeat testing:

model series	Year of production	lfd. Number

2. Safety instructions

2.1 Basic safety information/official safety regulations

The relevant national and international regulations should be observed. Failure to comply with the regulations or legal provisions and accident prevention regulations can result in personal injuries, injuries to others and property damage. Observe the safety instructions in these operating instructions at all times.

For the operation of the Blitz captive bolt stunner, the respective valid version of the accident prevention regulation "Working with shooting devices" (DGUV regulation 56) from the employers' mutual insurance association must be precisely observed and taken into account.

The device and the blank cartridges must be stored safely, protected from unauthorized use.

2.2 Improper use



It is not permitted to carry out modifications to the devices. It is forbidden to operate the captive bolt stunner in potentially explosive atmospheres or flammable atmospheres. Observe the information on operation, maintenance and care provided in these operating instructions.



Never point the device towards yourself or other persons. Do not press the device against your hand or other parts of the body. Ensure that the device is not fired when it is not pressed against an appropriate target.

2.3 Latest engineering practice

The captive bolt stunners have been constructed in accordance with the latest engineering practice. Any device can present a hazard if handled improperly or used for purposes other than its proper intended purpose.

If the operating instructions as well as the operational specifications and the accident prevention regulations are complied with, the device is operationally safe. Nevertheless, the device still poses some hazards that cannot be eliminated constructively. These include:

- » Risk of injury to fingers and hands
- » Hearing damage due to noise in the event of noise emissions greater than 75 dB(A)
- » Risk of injury due to negligence regarding the use of personal protective equipment during operation of the machine, during maintenance and repair work and during cleaning and disinfection

Additionally, despite all precautionary measures taken, non-obvious residual risks remain. The residual risks can be minimized if you observe the safety instructions as well as the operating instructions as a whole.

2.4 Appropriate use and environment



Ensure there is good lighting (observe workplace regulations). The device may only be used when held in the hand. Ensure that you have a secure footing and that you are well balanced. Avoid unusual postures. Keep other people away from the working area. Keep the sleeve dry, clean and free of oil and grease. Clean the device regularly.

2.5 General hazards caused by the device

The device may only be used when in flawless condition and in accordance with its intended purpose. Never leave a loaded device unsupervised. Always unload the device before cleaning and maintenance work as well as before storage.



Cock the device only immediately before stunning an animal.

Unused cartridges and devices that are not currently in use must be stored in the original packaging, protected from moisture and excessive heat. The device and the cartridges are to be stored such that they are secured against unauthorized use.

2.6 Thermal hazard

Do not exceed the stipulated max. firing frequency (number of shots per hour = 17), as otherwise this could result in burns. Do not dismantle the device when it is hot!



2.7 Cartridges that fail to fire

If a cartridge fails to fire, wait at least 30 seconds before removing the cartridge. Hold the device in a secure and safe position. After 30 seconds, remove the cartridge from the device and dispose of it properly.

2.8 Requirements for the user and personnel restrictions

The device is intended for use by adults and professional users. It is forbidden to pass the device on to minors. Butchers' trainees are an exception to this. Keep the device away from children and never leave it unsupervised.

The device may be operated and cleaned exclusively by authorized and trained personnel.

Always pay careful attention when working with or on the device. Work deliberately and do not use the device if you are not able to concentrate or if you are distracted. Stop working if you feel unwell. Observe the animal closely and be prepared for the animal moving around to avoid you or the device.

2.9 Personal protective equipment



The user and any other persons who are in the immediate vicinity must wear hearing protection whilst the device is being used.

3. Description

The device is subject to the EC Machinery Directive 2006/42/EC Annex 1, Point 2.2.2 "Portable fixing and other impact machinery."

The device is to be stored such that it is secured against unauthorized use.

After igniting the propellant charge in the cartridge receiver, the bolt accelerates, projects a defined distance out of the sleeve and is then withdrawn back into the housing (exception: Bullen Blitz), after which it remains in the device. Caliber 9x17, central fire cartridges must be used exclusively as the propellant device. **For safe use, the cartridges used in this device must fulfill the requirements of the corresponding C.I.P. approvals testing.** For optimum results, we recommend using turbocut blank cartridges or products of equivalent quality.

Functional principles of the captive bolt stunner

The energy from the blank cartridge is transferred to the bolt, accelerating it so that it penetrates the brain of the animal through the skullcap. The integrated bolt spring and the rubber buffer brake the bolt back to a standstill and push it back into the device (applies to the models Blitz Kerner and Kleiner Blitz only).

To achieve optimum results and to protect the device, the energy of the blank cartridge is tailored to the animal (see chapter 4 – Blank cartridges).

The Bullen Blitz model does not have a bolt spring. A retaining system is used in this case. This model series was specially developed for the heavier animals. The device has a larger projection length for the bolt than the other captive bolt stunner models.

With the Blitz Schlag model series, the method used is the application of a percussive blow to the head. This device is designed exclusively for stun-

ning poultry, rabbits, and hares with a live weight of 5 kg or more. You will find further details regarding the captive bolt stunner in chapter 10 – Technical data.

You will find more information at www.turbocut.de

For further information, please scan this QR code:



4. Blank cartridges and their storage

The captive bolt stunner apparatuses have been specially developed for the central fire cartridges (9x17 caliber, folded closed and watertight) – **only these cartridges may be used!**

The blank cartridges are available in four different strength levels for the different types of animals to be slaughtered. Particular care should be taken with the respective selection in accordance with the type of animal and the size of the animal.

The selection of the correct charge strength for the respective animal ensures species-appropriate stunning and helps to reduce the wear on the bolt spring and rubber buffer. The printed information, the color of the label and the color of the primer indicate the charge strength of the blank cartridges. See the following table for recommendations:

Cartridge	Charge strength	Model series	Type of animal
Green	Weak charge	Blitz Kerner	Piglets (5 kg up to 30 kg), sheep/goats less than 1 year old
		Kleiner Blitz	Piglets up to 5 kg
		Blitz Schlag	Poultry and rabbits 5 kg and over
Yellow	Medium charge	Blitz Kerner	Sheep and goats (1 year and over) Horses, fattened pigs, cows (crossbreed under 500 kg), cows meat breed under 450 kg
Blue	Strong charge	Blitz Kerner	Medium oxen and young bulls
Red	Very strong charge	Blitz Kerner	Cows up to 650 kg
		Bullen Blitz	Cows with live weights of 650 kg and over, large sows and boar

The captive bolt stunner can be guaranteed to operate properly if blank cartridges and spare parts that are tested and approved by us are used.

Storage

The blank cartridges should be stored in a dry location and protected from unauthorized use. They must be protected from heat and kept away from naked flames and other ignition sources.

Do not store them together with flammable or other materials that increase the likelihood of hazards. The national legal provisions are to be observed.

The blank cartridges should be stored exclusively in the original manufacturer's packaging.

Storage temperature	Recommended storage temperature	Relative humidity
0°C up to +30°C	+20°C	max. 60%

5. First use

The Regulation on the protection of animals at the time of killing stipulates that the correct function of the captive bolt stunner must be checked at least once before the start of work every day.

5.1 Checking device

Recommended before and after each use!

Ensure that there is no blank cartridge in the cartridge receiver. The active parts must exhibit no corrosion!

Check the position of the bolt. To do so, hold the device vertically with the exit opening pointing downwards. The bolt must be at least 4 mm inside the sleeve and must hold itself in place there (see chapter 7 – Troubleshooting).

Should the bolt stand back less than indicated or even be flush or protrude from the sleeve, the bolt cannot be freely accelerated. In this case, the bolt spring and the rubber buffer must be replaced.

Check the rubber buffer and the bolt spring for wear before use. The lock must be screwed in flush with the sleeve.

Never use the device without a rubber buffer or a bolt spring!

5.2 Alternative methods

Test the device with a test block and/or a speed measurement device and document this test.

You can also find further advice in our video guide on checking for wear on our website or directly with this link:

You will find more information at www.turbo-cut.de

For further information, please scan this QR code:



6. Operating the device

Read through these operating instructions carefully before first use and use the sketches of the individual captive bolt stunners found in the appendix for better understanding.

Use hearing protection (user and persons in the vicinity). Noises that are too loud can damage your hearing.

Please check that the captive bolt stunner is complete and that it is functioning properly and operationally capable before use!

Operating the device without a rubber buffer or a bolt spring is not permitted!

Never point the device towards yourself or other persons!

Watch out for sudden, evasive movements by the animal!

It is absolutely mandatory that the animal be restrained or according to the applicable regulations.



6.1 Loading

Unscrew the headpiece counter-clockwise, insert a blank cartridge (caliber 9x17 central fire) with the primer (colored point) facing upwards, into the intermediate piece. Screw the headpiece on fully, clockwise, hand-tight. Ensure that the annular spring is not twisted.

The opening of the annular spring must lie opposite the trigger!

6.2 Cocking

Pull the striking pin out by the striking pin nut until the trigger can be heard latching into place.

The captive bolt stunner is now ready to fire.



When loading the blank cartridge and cocking the striking pin, the device must be held such that it is not pointed towards the operator's own body or other people.

The captive bolt stunner must be cocked only immediately before firing (actuating the trigger)!



The device must not be held by the muzzle. Never hold the bottom end of the device (where the bolt emerges) against the body – even when looking for potential faults.

If a loaded captive bolt stunner is not to be fired immediately, it should be unloaded!

6.3 Firing

To fire the device, it should be held securely with both hands. The guiding hand should be near the trigger. The holding hand should be underneath. Then position the lock quietly and carefully but then firmly against the skull of the animal and trigger the device quickly. The shot is fired by pressing on the trigger with one or two fingers – press all the way down. This triggers the bolt and stuns the animal.

The figures in chapter 6.5 show the positions where the captive bolt stunner must be placed for the individual types of animal.

The device is to be applied to the optimal stunning point of the skullcap for the specific animal, as close to perpendicular as possible. In the case of fattened pigs, the stunning apparatus should be applied at a downwards angle of 25° to the vertical line. The optimal strike point prevents the bolt from becoming jammed in the skull.

Test shots into the air are to be avoided.

Always fire test shots only into adequately strong and firmly mounted wooden supports (square timber min. 10 x 10 cm).

In the event of ammunition failing, the triggering mechanism must be actuated again. If there is still no ignition, please wait around 30 seconds; then unscrew the headpiece completely and remove the ammunition carefully by means of the trigger.

The striking pin must not be cocked at this time.



Testing the striking pin

With the headpiece unscrewed, ensure that the tip of the striking pin does not project out of the headpiece as otherwise this could result in premature firing when it is screwed back on again. If the striking pin is defective, it can only be replaced as a complete unit. To do so, order a complete striking pin set.



Maintenance work must be carried out exclusively by the manufacturer or their authorized representatives unless the user is installing only parts designated as replacement parts (see chapter 13.2 – Accessories and spare parts lists) by the manufacturer within the scope of their maintenance work.



6.4 Removing the fired blank cartridges

After unscrewing the headpiece, the blank cartridge can usually be easily removed with the fingers. If the blank cartridge is jammed, it can be removed with the extractor located at the end of the trigger by hooking it into the groove on the intermediate piece (cartridge receiver).

The cartridge receiver should then be immediately cleaned of any powder residue and other contaminants with the small brush.

6.5 Positioning for various animal breeds

For cows, the captive bolt pistol is to be positioned 1-3 cm above the center of the intersection point center horn/imaginary horns to center eye. The older the animal, the higher the position. The device is to be applied vertically to the forehead (at right angles).



Meat breeds, crossbreeds, large sows and boars as well as animals with high live weights of 650 kilograms and more should be stunned with the Bullen Blitz!

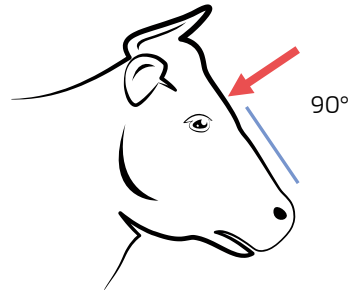
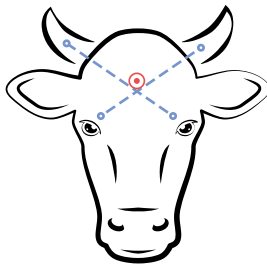

Positioning and angle for **heavy animals** with the Bullen Blitz:

For animals with horns, the device is to be positioned approx. 1-3 cm above the imaginary intersection point from the center of the horns to the center of the eyes.

For animals without horns, the device is to be positioned according to the "imaginary" horns.

For animals with a clear bone ridge along the center line of the forehead, the device should be positioned 1 cm to the side.

For cows, the stunning apparatus is to be positioned vertically to the forehead surface; press the stunning apparatus firmly onto the animal's head!

Should there be strong hair growth on the animal's forehead as is common in certain breeds, it is to be removed before stunning!

For **large sows and boars** with a steep forehead/snub nose, set the device vertically. The device is to be positioned centrally, approx. 2-3 cm above the imaginary connecting line of the eye points (<150 kg=2 cm above; >150 kg=3 cm above).

In the case of **fattened pigs** with cuneiform heads, the device is to be positioned approx. 1 cm above the line of the eye centerpoints, toward the outer ears. The application angle is approx. 65 degrees.

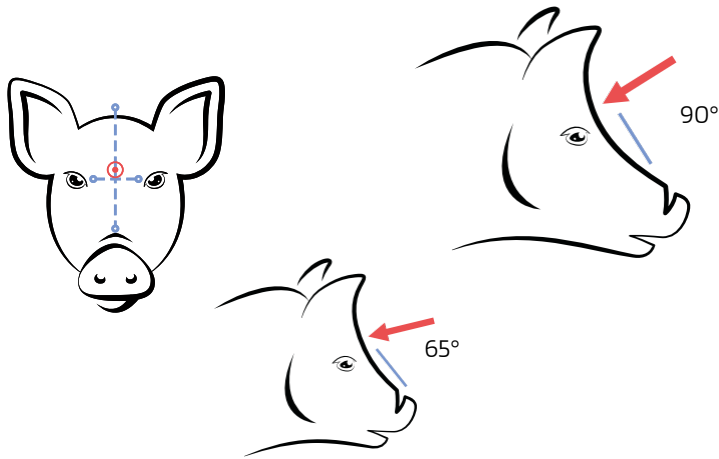

Note: The use of captive bolt pistols for pigs is a replacement method and thus may be used only if the approved stunning method fails and in home slaughtering!

Horses are to be shot vertically to the forehead, at the intersection point center eyes to center ears.



Goats and sheep with horns are to be shot directly behind the horns or the bone ridge. In the case of unhorned sheep, the device is to be positioned at the highest point of the skull. The shot must be fired straight downward.

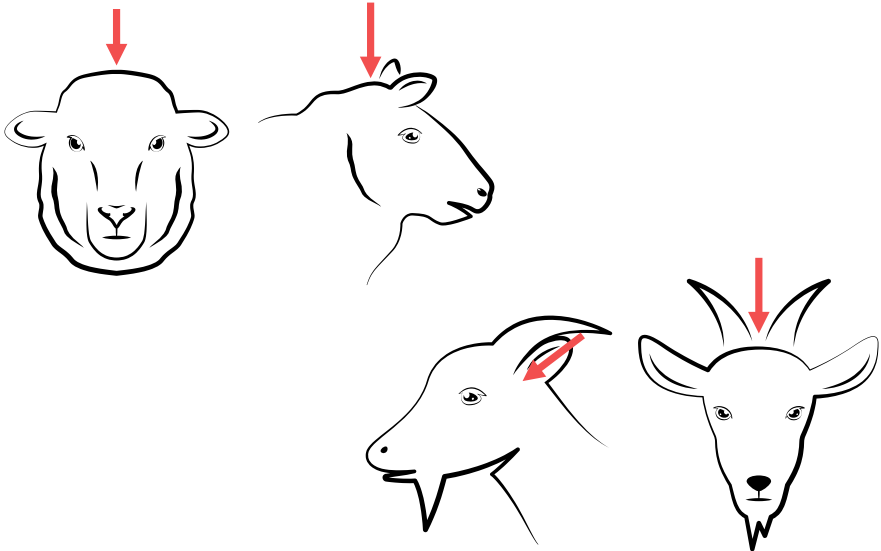

It is important that the head be restrained/held in place. This is done by supporting the lower jaw with the hand or pressing the neck against a wall.

The use of a captive bolt pistol alone is not a method for slaughter! Only if vital brain stem areas are also destroyed (breathing, blood pressure, heart rate) can this lead to the death of the animal. To ensure certain death, the animal stunned by the shot must be bled within 60 seconds after the shot.

The aim of the shot is to properly stun the animal before the bleeding cut!

Adequate stunning can be achieved only if the stunning device is applied accurately. The animal must be restrained to prevent it from moving; therefore, the animal's head in particular must be moved into and fixed in such a position that the stunning device can be applied and operated without any problem.

Since the bolt is not fully retracted after the shot, it can remain inside the skull when the animal slumps down.



The entire process should be carried out as calmly as possible to spare the animal stress and suffering!

6.6 Signs of a good stunning effect

- » Immediate collapse
- » in the numb phase, head extended, legs pulled under the stomach, then slow stretching, no attempts to stand up
- » in the subsequent convulsion phase, uncoordinated twitchy movements
- » Eyes rigid, pupil dilated and remains wide
- » No eyelid and corneal reflex (no blinking when touching the eyelashes or cornea)
- » No breathing movements detectable on nose, mouth or body

After 60 seconds:

- » No movements
- » Tongue hangs out of the mouth
- » Tail and ears limp
- » Straight dorsal line (in the case of suspended bleeding)

For further information, we recommend the website of BSI Schwarzenbek:

http://www.bsi-schwarzenbek.de/Dokumente/bsi%20StandardsBetaeubungseffektivitaet_Rd_Sw_Sf%209_2020.pdf



7. Troubleshooting

CARTRIDGE DOES NOT FIRE

Wait approx. 30 seconds. Then carefully open the headpiece by loosening it by about anticlockwise 2 turns. Then remove the non-fired cartridge and replace it with a new one.

Before inserting a new cartridge, check the striking pin. The tip of the striking pin, in particular, could be deformed or contaminated.

However, most often the cause of the fault lies with the blank cartridge. Moisture can result in a complete failure – or also a significant reduction in performance. Check the blank cartridge for corrosion and check the impression of the striking pin tip on the primer.

Unclear situation:

The captive bolt stunner must be sent in to turbocut Jopp GmbH for testing.

BOLT DOES NOT PENETRATE DEEPLY ENOUGH

Check whether the correct blank cartridge charge strength has been selected and check whether the interior of the device is badly contaminated. In the latter case, clean thoroughly. It must be possible to move the bolt backwards and forwards easily after removing the bolt spring and the rubber buffer. By rolling the bolt on a flat surface, you can check whether the bolt is bent in a manner not permitted.

Hold the captive bolt stunner vertically with the exit opening pointing downwards. The bolt must be 4 mm inside the sleeve. If it reaches the edge of the exit opening or if it is already protruding from it, the rubber buffer and the bolt spring must be replaced immediately (wear set). An evasive movement by the animal or incorrect restraining of the head of the animal can result in a failed shot.

THE BOLT DOES NOT SPRING BACK

In unfavorable cases, the bolt can jam in the skull of an animal. After being withdrawn and cleaned, if necessary, the bolt should be pulled into the sleeve. Otherwise, the bolt could be bent. (Rolling test) The device could also be contaminated – see chapter 9 – the bolt spring (Bullen Blitz does not have a spring) and/or rubber buffer could also be worn. The device requires maintenance. Components must be replaced (wear set).

BOLT SPRING AND RUBBER BUFFER WEAR PREMATURELY

This is often caused by the use of more powerful blank cartridges than stipulated. This can also be an indication of unsuitable ammunition being used. Use cartridges appropriate to the type of animal.

TRIGGER CANNOT BE MOVED

The annular spring has twisted. The opening of the annular spring must always be opposite the trigger. The trigger mechanism is defective or the trigger is deformed. Send the device in for inspection immediately.

8. Maintenance and care

The captive bolt stunner is to be checked at least once when starting work and should be carefully cleaned several times as required to remove powder residues and prevent corrosion. Such residues can lead to functional faults and damage. Any defects detected should be rectified immediately. During all cleaning work, observe the corresponding hazardous substances ordinance with regard to the labeling and instructions for the materials used. The maintenance and repair shall be carried out only by capable, authorized and trained personnel!

Use of original parts is always essential to ensure that the safety of the device is maintained!

Procedure for maintenance and care

- » Use hand protection (in order to prevent contact reactions)
- » Unscrew headpiece in unloaded condition
- » Unscrew lock
- » Remove bolt spring (only applicable to the Blitz Kerner and Kleiner Blitz models), rubber buffer and bolt



Carefully clean the interior walls of the sleeve, the bolt, the bore of the intermediate piece, the exterior of the device and all of the other parts with the provided brushes, which are to be screwed onto the cleaning rod. Coarse deposits and dirt should be wiped off beforehand with suitable cleaning oil (e.g. Ballistol). Check the bolt in particular for corrosion as rust will reduce the firing force and could result in embrittlement or hairline cracks. A corroded bolt must be replaced.

The dried parts should be lightly oiled with machine oil. Keep the rubber buffer free of oils. Check the rubber buffer and the bolt spring for damage and wear.

In the Kleiner Blitz and Blitz Schlag models, the position of the rubber buffers should be swapped after every cleaning in order to guarantee the longest possible service life.

Re-insert the bolt, rubber buffer and bolt spring in this order again and screw the lock flush against the sleeve. The bolt must not protrude out of the lock. It is likewise recommended that the headpiece be washed in cleaning oil without being dismantled and then lightly oiled with machine oil.

Check the correct function of the device by feeding the cleaning rod provided into the empty intermediate piece and pressing the bolt out against the force of the spring (only applicable to models BK and KB). The bolt must then protrude from the bottom end of the device and must be fully retracted into it again when the cleaning rod is withdrawn. The cartridge receiver should also be cleaned. For this, use the small brush.

9. Disposal

The Blitz captive bolt stunners from turbocut Jopp GmbH are manufactured with a high proportion of recyclable materials.

By recycling some parts and raw materials, you make an important contribution to protecting the environment.

An important prerequisite for recycling is the proper separation of materials. If the device is submitted for material separation, dismantle the device to the extent possible without special tools.

Contact your local authorities if you require information about collection points in your area.

Please dispose of all parts of the device in such a way that health and environmental damage is ruled out.

Note on non-fired cartridges:

Proper disposal or return to manufacturer.

Separation of the individual parts

Component	Main material	Recycling
Rubber buffer	Elastomers	Household waste
Trigger clip	Plastic	Plastic recycling
All other components	Steel	Scrap metal

Even if the disposal is carried out by an approved specialist company, the operator of a captive bolt stunner must ensure proper implementation!



10. Technical data

Data \ Model series	Blitz Kerner	Bullen Blitz	Kleiner Blitz	Blitz Schlag
Article number	3071014	3071008	3071009	3071010
Short description	BK-014	BB-008	KB-009	BS-010
Type of penetration	penetrating	penetrating	penetrating	non-penetrating
Bolt projection length	approx. 82 mm	approx. 122 mm	approx. 52 mm	approx. 10 mm
Weight	2,21 kg	2,60 kg	2,23 kg	2,25 kg
Device length in uncocked state	330 mm	360 mm	330 mm	330 mm
Sleeve diameter	40 mm			
Max. firing frequency	17 shots per hour			
Cartridges, caliber	9 x 17 mm - central fire			
Power	1,2,3,4 *	4*	1*	1*

*1 = green cartridges, 2 = yellow cartridges, 3 = blue cartridges, 4 = red cartridges

Acoustic measurement for fastener driving devices GK2 dt. Fassung EN 12549:1999+A1:2008; Red cartridge (460mg propellant powder)	
Noise pressure level at measurement surface	98 dB(A)
Emitted noise pressure at workplace (max. 17 shots/h)	82 dB(A)
Sound power level	111 dB(A)
Peak noise pressure level	139 dB(A)

Key parameters acc. to 1099/2009/EC Speed ± 2 m/s and resulting energy for cartridges				
Kartusche	Blitz Kerner	Bullen Blitz	Kleiner Blitz	Blitz Schlag
Green	42m/s - 185J		42m/s - 185J	20m/s - 50J
Yellow	46m/s - 222J			
Blue	47m/s - 232J			
Red	49m/s - 252J	53m/s - 323J		

Vibration measurement with red cartridge (460mg) nach DIN EN ISO 5349-1, 20643 und DIN ISO/TS 15694 und 8662-11	
Total vibration at 17 shots/h	2,5m/s ²

11. Test specifications and repeat testing

Within the scope of the applicability of the industrial safety regulations, the operator of a captive bolt stunner must submit the device to the manufacturer or their appointed representative for testing **within 2 years**, rounded up to the end of the month, or immediately in the case of significant functional defects.

The period for the first repeated test starts with the shipping of the device to the operator.

The start of this period should be verified through a purchase certificate, which the manufacturer or dealer will have enclosed when handing over each captive bolt stunner. The corresponding form can be filled in by the operator or dealer on the last page of these operating instructions as proof.

12. Manufacturer warranty

turbocut Jopp GmbH warrants that its captive bolt stunners are free of material and manufacturing defects. This warranty applies with the prerequisite that the device be properly used, handled, cared for and cleaned in accordance with these operating instructions and that it be maintained as a technical unit.

This means that only original consumables, accessories and spare parts or other products of equivalent quality are to be used with the captive bolt stunner.

This warranty encompasses repair or replacement of defective parts free of charge throughout the entire service life of the device. Parts that are subject to normal wear, for example the rubber buffer and the bolt spring, are not covered by this warranty.

Further claims are excluded insofar as this does not contravene any mandatory national or international regulations. In particular, turbocut Jopp GmbH shall not be liable for direct or indirect defects or consequences of defects, losses or costs in conjunction with the use of the captive bolt stunner for any purpose whatsoever. Implied assurance for the use or suitability for a particular purpose is expressly excluded.

The captive bolt stunner and/or affected parts must be returned to the manufacturer or their appointed representative for repair or replacement immediately after discovery of a defect.

This warranty declaration encompasses all warranty obligations on the part of turbocut Jopp GmbH for the Blitz captive bolt stunner and replaces all earlier or simultaneous declarations, written or verbal agreements with regard to warranty services.

C.I.P. Test confirmation

The Blitz captive bolt stunner apparatuses from turbocut Jopp GmbH are type-approved and system-tested. For this reason, the device is furnished with a PTB approval number and is registered with the above-named authority under: DE-17-MARLIV18-PTB01.

With this, turbocut Jopp GmbH guarantees the compliance of each captive bolt stunner with the approved design.

Impermissible defects discovered during use are to be reported to the responsible manager of the approvals authority (PTB) as well as the office of the Permanent International Commission (C.I.P.).

13. Appendix

13.1 Sketches of the captive bolt stunners

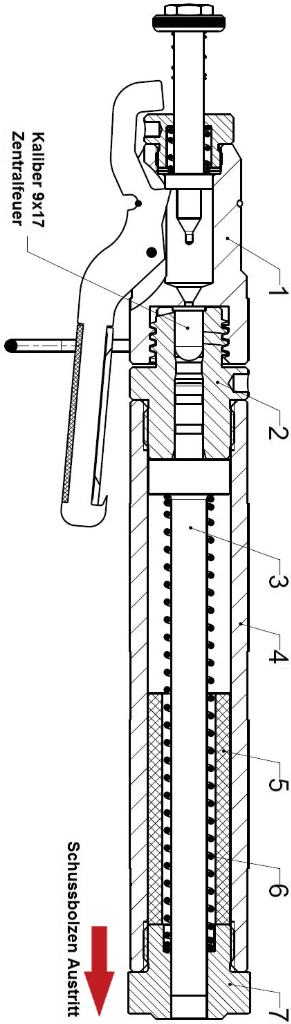

fig.: captive bolt stunner
Blitz Kerner
(loaded and tensioned)

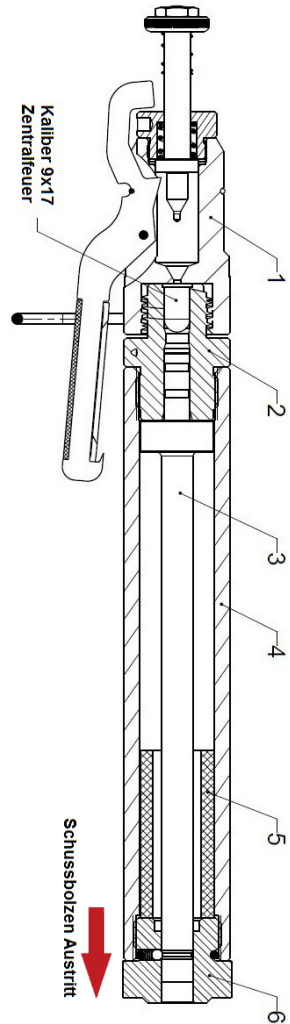

fig.: captive bolt stunner
Bullen Blitz
(loaded and tensioned)

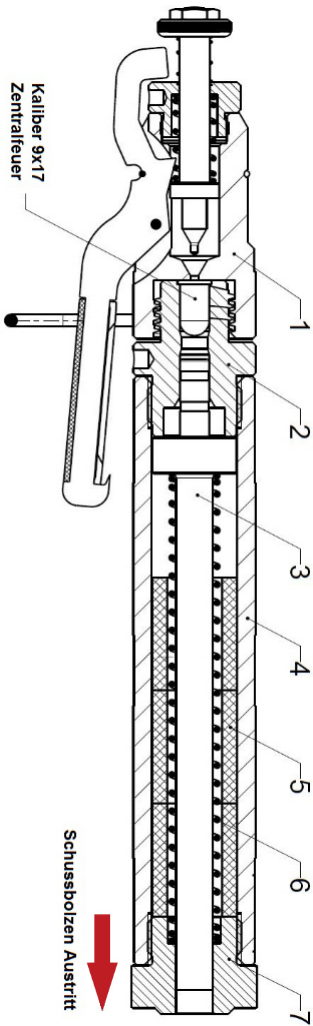

fig.: captive bolt stunner
Kleiner Blitz
(loaded and untensioned)

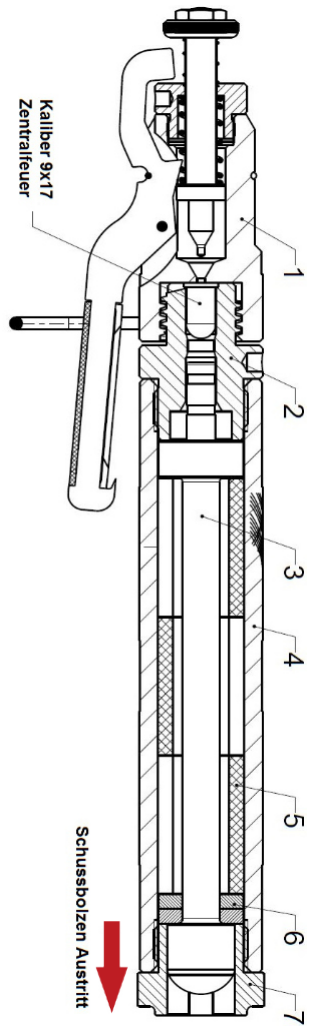

fig.: captive bolt stunner
Blitz Schlag
(loaded and untensioned)

13.2 Accessories and spare parts

In this chapter you will find suitable accessories and the spare part designations for the illustrations of the captive bolt stunners from chapter 13.1.

Spare part list for the Blitz Kerner captive bolt stunner article no.: 3071014		
Position	Description	Article no.
1	Complete headpiece	3080260*
2	Intermediate piece (black)	3080261*
3	Bolt	3080225*
4	Sleeve	3080282
5	Rubber buffer	3086088*
6	Bolt spring	3086093*
7	Lock	3080157*

The articles nos. marked with *) are available as spare parts and/or wear sets.

Spare part list for the Bullen Blitz captive bolt stunner article no.: 3071008		
Position	Description	Article no.
1	Complete headpiece	3080260*
2	Intermediate piece (black)	3080261*
3	Bolt	3080272*
4	Sleeve	3080288
5	Rubber buffer	3080271*
6	Complete lock	3080279*

Spare part list for the Kleiner Blitz captive bolt stunner article no.: 3071009

Position	Description	Article no.
1	Complete headpiece	3080260*
2	Intermediate piece (green)	3080251*
3	Bolt	3080225*
4	Sleeve	3080286
5	Rubber buffer (3x)	3080270*
6	Bolt spring	3086093*
7	Lock	3080157*





Spare part list for the Blitz Schlag captive bolt stunner article no.: 3071010

Position	Description	Article no.
1	Complete headpiece	3080260*
2	Intermediate piece (green)	3080251*
3	Bolt	3080254*
4	Sleeve	3080284
5	Rubber buffer (3x)	3080290*
6	Spacer (2x)	3080291*
7	Lock	3080253*

You can obtain the following accessories via our Internet shop:

Description	Article no.
Complete striking pin	3080222
Cleaning set	3080231
Blitz Kerner wear set	3080228
Bullen Blitz wear set	3080280
Kleiner Blitz wear set	3080277
Blitz Schlag wear set	3080292
Original operating instructions (printed version on request)	3080306

Additionally, the following blank cartridges are available on our Internet shop:

	Description	Article no.
	Green blank cartridge (weak charge)	3072002
	Yellow blank cartridge (medium charge)	3072001
	Blue blank cartridge (strong charge)	3072004
	Red blank cartridge (very strong charge)	3072003



You will find more information at www.turbocut.de

For further information, please scan this QR code:

14. Declarations of Conformity

Blitz Kerner (translation)

EC declaration of conformity for Blitz Kerner (translation)

We, the manufacturer:

turbocut Jopp GmbH
Donsenhaus 4
D-97616 Bad Neustadt
Telefon: +49 (0) 9771/9105-366
Telefax: +49 (0) 9771/9105-368
Internet: www.schussapparate.de
E-Mail: info@turbocut.de

hereby declare that the Blitz livestock stunning device manufactured by us with the model designation **BK-014** cited on the device, complies with the following directives:

2006/42/EC Directive 2006/42/EC of the European Parliament and Council from the 17th May 2006 regarding machinery and the amendment to Directive 95/16/EC (new version) (1)

The office designated for data EC type approval test is:

Physikalisch Technische Bundesanstalt
Bundesallee 100
D-38116 Braunschweig

Identification number for the designated authority: 0102
EC type test certificate: DE-17-MARLIV18-PTB01

With the manufacturing of the product, the following harmonised standards were applied in accordance with the directive per article 7 section 2:

DIN EN ISO 12100:2011-03 Safety of machinery – General design principles – Risk assessment and risk reduction (ISO 12100:2010)

The authorised representative at turbocut Jopp GmbH for compiling the technical documentation is:

Dr. Hubert P. Büchs
Donsenhaus 4
D-97616 Bad Neustadt



Dr. Hubert P. Büchs
Managing Director

Bad Neustadt, den 22.03.2018

address:
turbocut Jopp GmbH
Donsenhaus 4
D-97616 Bad Neustadt

contact:
www.turbocut.de • www.schussapparate.de
E-Mail: info@turbocut.de
Telefon: +49 (0) 9771 / 9105-0
Telefax: +49 (0) 9771 / 9105-368

business data:
Amtsgericht Schweinfurt HRB 4818
Ust.Id.Nr.: DE814496587
Geschäftsführer:
Dr.-Ing. Hubert P. Büchs

Bullen Blitz (translation)

EC declaration of conformity for Bullen Blitz (translation)

We, the manufacturer:

turbocut Jopp GmbH
Donsenhaus 4
D-97616 Bad Neustadt
Telefon: +49 (0) 9771/9105-366
Telefax: +49 (0) 9771/9105-368
Internet: www.schussapparate.de
E-Mail: info@turbocut.de

hereby declare that the Blitz livestock stunning device manufactured by us with the model designation **BB-008** cited on the device, complies with the following directives:

2006/42/EC Directive 2006/42/EC of the European Parliament and Council from the 17th May 2006 regarding machinery and the amendment to Directive 95/16/EC (new version) (1)

The office designated for data EC type approval test is:

Physikalisch Technische Bundesanstalt
Bundesallee 100
D-38116 Braunschweig

Identification number for the designated authority: 0102
EC type test certificate: DE-17-MARLIV18-PTB01

With the manufacturing of the product, the following harmonised standards were applied in accordance with the directive per article 7 section 2:

DIN EN ISO 12100:2011-03 Safety of machinery – General design principles – Risk assessment and risk reduction (ISO 12100:2010)

The authorised representative at turbocut Jopp GmbH for compiling the technical documentation is:

Dr. Hubert P. Büchs
Donsenhaus 4
D-97616 Bad Neustadt

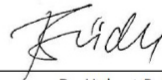

Dr. Hubert P. Büchs
Managing Director

Bad Neustadt, den 22.03.2018

address:
turbocut Jopp GmbH
Donsenhaus 4
D-97616 Bad Neustadt

contact:
www.turbocut.de • www.schussapparate.de
E-Mail: info@turbocut.de
Telefon: +49 (0) 9771 / 9105-0
Telefax: +49 (0) 9771 / 9105-368

business data:
Amtsgericht: Schweinfurt HRB 4818
Ust.Id.Nr.: DE814496587
Geschäftsführer:
Dr.-Ing. Hubert P. Büchs

Kleiner Blitz (translation)

EC declaration of conformity for Kleiner Blitz (translation)

We, the manufacturer:

turbocut Jopp GmbH
Donsenhaus 4
D-97616 Bad Neustadt
Telefon: +49 (0) 9771/9105-366
Telefax: +49 (0) 9771/9105-368
Internet: www.schussapparate.de
E-Mail: info@turbocut.de

hereby declare that the Blitz livestock stunning device manufactured by us with the model designation **KB-009** cited on the device, complies with the following directives:

2006/42/EC Directive 2006/42/EC of the European Parliament and Council from the 17th May 2006 regarding machinery and the amendment to Directive 95/16/EC (new version) (1)

The office designated for data EC type approval test is:

Physikalisch Technische Bundesanstalt
Bundesallee 100
D-38116 Braunschweig

Identification number for the designated authority: 0102
EC type test certificate: DE-17-MARLIV18-PTB01

With the manufacturing of the product, the following harmonised standards were applied in accordance with the directive per article 7 section 2:

DIN EN ISO 12100:2011-03 Safety of machinery – General design principles – Risk assessment and risk reduction (ISO 12100:2010)

The authorised representative at turbocut Jopp GmbH for compiling the technical documentation is:

Dr. Hubert P. Büchs
Donsenhaus 4
D-97616 Bad Neustadt



Dr. Hubert P. Büchs
Managing Director

Bad Neustadt, den 22.03.2018

address:
turbocut Jopp GmbH
Donsenhaus 4
D-97616 Bad Neustadt

contact:
www.turbocut.de • www.schussapparate.de
E-Mail: info@turbocut.de
Telefon: +49 (0) 9771 / 9105-0
Telefax: +49 (0) 9771 / 9105-368

business data:
Amtsgericht Schweinfurt HRB 4818
Ust.IdNr.: DE814496587
Geschäftsführer:
Dr.-Ing. Hubert P. Büchs

Blitz Schlag (translation)

EC declaration of conformity for Blitz Schlag (translation)

We, the manufacturer:

turbocut Jopp GmbH
Donsenhaus 4
D-97616 Bad Neustadt
Telefon: +49 (0) 9771/9105-366
Telefax: +49 (0) 9771/9105-368
Internet: www.schussapparate.de
E-Mail: info@turbocut.de

hereby declare that the Blitz livestock stunning device manufactured by us with the model designation **BS-01Q** cited on the device, complies with the following directives:

2006/42/EC Directive 2006/42/EC of the European Parliament and Council from the 17th May 2006 regarding machinery and the amendment to Directive 95/16/EC (new version) (1)

The office designated for data EC type approval test is:

Physikalisch Technische Bundesanstalt
Bundesallee 100
D-38116 Braunschweig

Identification number for the designated authority: 0102
EC type test certificate: DE-17-MARLIV18-PTB01

With the manufacturing of the product, the following harmonised standards were applied in accordance with the directive per article 7 section 2:

DIN EN ISO 12100:2011-03 Safety of machinery – General design principles – Risk assessment and risk reduction (ISO 12100:2010)

The authorised representative at turbocut Jopp GmbH for compiling the technical documentation is:

Dr. Hubert P. Büchs
Donsenhaus 4
D-97616 Bad Neustadt



Dr. Hubert P. Büchs
Managing Director

Bad Neustadt, den 22.03.2018

address:
turbocut Jopp GmbH
Donsenhaus 4
D-97616 Bad Neustadt

contact:
www.turbocut.de • www.schussapparate.de
E-Mail: info@turbocut.de
Telefon: +49 (0) 9771 / 9105-0
Telefax: +49 (0) 9771 / 9105-368

business data:
Amtsgericht Schweinfurt HRB 4818
USt.LiD.Nr.: DE81A496587
Geschäftsführer:
Dr.-Ing. Hubert P. Büchs

15. For your notes

16. Important information on purchase certificate

The operator of a captive bolt stunner must submit the device to the manufacturer or their appointed representative for inspection within 2 years, rounded up to the end of the month, or immediately in the case of significant functional defects.

The period for the first repeated test starts with the shipping of the device to the operator. The start of this period should be verified by means of a purchase certificate (see reverse page), which the manufacturer will have enclosed when handing over each captive bolt stunner to the operator.

To ensure that you do not miss the first appointment, we recommend that you keep this certificate stored safely with your schedule documents.

The operating instructions must be observed and must be kept safely with the captive bolt stunner throughout the entire period of its use.



It is not permitted carry out modifications to the captive bolt stunner!

Never point the device towards yourself or other persons!

The device and the blank cartridges are to be stored in a dry location and in such a way as to ensure that they are secured against unauthorized use!

Manufacturer :

turbocut Jopp GmbH
D-97616 Bad Neustadt an der Saale

Contact :

turbocut Jopp GmbH
Donsenhaus 4
D-97616 Bad Neustadt an der Saale
Telefon:+49 (0) 9771 / 9105-328
Fax: +49 (0) 9771 / 9105-368
E-Mail: info@turbocut.de
Internet: www.turbocut.de



Here you come directly to
our internet shop
www.turbocut.de

Just scan this QR code

Purchase certificate

This certificate serves to verify the start of the period in accordance with the manufacturer's instructions.

Please transfer (you or your dealer) the necessary information from the delivery note and/or invoice to this certificate.

The turbocut Jopp GmbH Blitz captive bolt stunner

model series	
with apparatus number	
was delivered	
by the company/dealer	
to	
with the receipt/invoice number	

Dates for repeat testing

1	
2	
3	
4	
5	

Company/dealer, date, signature, dealer stamp (if applicable)